

# Regulations – Land Development Code Excerpts

## Outdoor Lighting

Manatee County, Florida

Selected content from Ordinance 05-37

Adopted September 20, 2005 by the Manatee County Board of County Commissioners

Manatee County Land Development Code  
Excerpts related to outdoor lighting

## Table of Contents

<b>Definitions</b> .....	3
<i>Fixture</i> .....	3
<i>Footcandle</i> .....	3
<i>Full horizontal shielding</i> .....	3
<i>Full oblique shielding</i> .....	4
<i>Light source</i> .....	4
<i>Lumen</i> .....	4
<i>Protected area</i> .....	5
<i>Shield</i> .....	5
<i>Shielding Angle</i> .....	5
<b>Amendments to Official Zoning Atlas</b> .....	6
<i>Factors for Reviewing Proposed Amendments</i> .....	6
<b>Site Plans</b> .....	7
<i>Final Site Plan Requirements</i> .....	7
<b>Lighting</b> .....	7
<i>Intent</i> .....	7
<i>Applicability</i> .....	7
<i>Exemptions</i> .....	7
<i>Low Intensity</i> .....	7
<i>Streets</i> .....	7
<i>Emergency</i> .....	8
<i>Construction</i> .....	8
<i>Road and Utility Repairs</i> .....	8
<i>Signs</i> .....	8
<i>Religious or National Symbols and Flags</i> .....	8
<i>Underwater Lamps</i> .....	8
<i>Safety</i> .....	8
<i>Illumination Limits</i> .....	8
<i>Direct Illumination</i> .....	8
<i>Driver Vision Impairment</i> .....	9
<i>Measurable Spill Illumination Limits</i> .....	9
<i>Fixture Height</i> .....	9
<i>Controllers, Timers and Sensors</i> .....	9
<i>Special Lights</i> .....	9
<i>Aerial Lights</i> .....	9
<i>Accent Lights</i> .....	10
<i>Boat Dock &amp; Marina Lights</i> .....	10
<i>Canopy Lights</i> .....	10
<i>Fascia Lights</i> .....	10
<i>Gas Pump, Convenience Business, Automatic Teller Machine, and other Required Security Lights</i> .....	10
<i>Outline Lights</i> .....	10
<i>Projection Lights</i> .....	10
<i>Required Lights</i> .....	10
<i>Stadium and Recreation Lights</i> .....	10
<i>Lighting Plan</i> .....	11
<i>Submittal</i> .....	11
<i>Fixture Locations</i> .....	11
<i>Fixture Detail</i> .....	11
<i>Fixture Height and Mounts</i> .....	11
<i>Direct Illumination Plots</i> .....	11
<i>Photometric Diagram</i> .....	12
<i>Review</i> .....	12
<i>Inspection</i> .....	13

**Section 201. Definitions.**

*Lighting, Outdoor.* (See “OUTDOOR LIGHTING.”)

*Lumen (Outdoor Lighting).* (See “OUTDOOR LIGHTING.”)

**OUTDOOR LIGHTING.**

*Fixture (Outdoor Lighting).* The light source, the lamp holder, the shields, and their housing in an assembly that may include other components, e.g., electrical devices. Including but not limited to: security, flood, spot, wall, fascia, back, advertising, landscape, foot path, accent, outline, swivel, directional, movable, portable, yard, seawall, or dock light.

*Footcandle (Outdoor Lighting).* The unit for measurement of illumination received by a surface located at a distance from a source of visible light. Typically calculated for a lighting plan and measured with a light meter.

*Full horizontal shielding (Outdoor Lighting).* A design for a fixture that does not emit light above the horizontal plane running through the lowest point on the light source. Does not include a drop lens, sag lens, or convex lens if the lens extends below the shield. Sometimes called *fully shielded* by manufacturers of outdoor lighting. The following illustrations provide examples:

The bulb, reflectors, or lens do not extend below the shield:

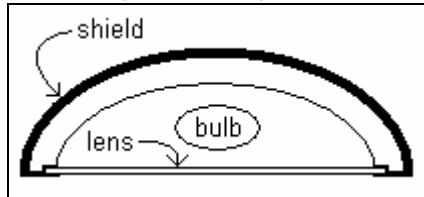

**Vertical cross section of fixture with *full horizontal shielding***

The illumination does not project above the fixture:

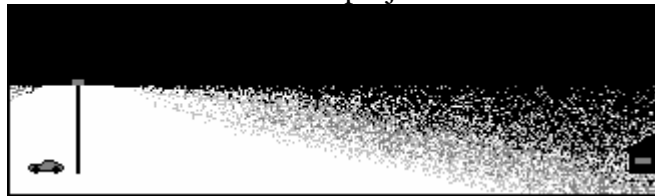

**Street lighting from fixture with *full horizontal shielding***

*Full oblique shielding (Outdoor Lighting).* A design for a fixture that does not emit light above the line of sight to the light source when viewed from protected property. The shield blocks direct illumination of protected property. The fixture completely conceals and recesses the light source from all viewing positions except those positions permitted to receive illumination. The following illustrations provide examples:

The interior surface of the shield below the lens has a dull and dark finish to prevent reflection of light.

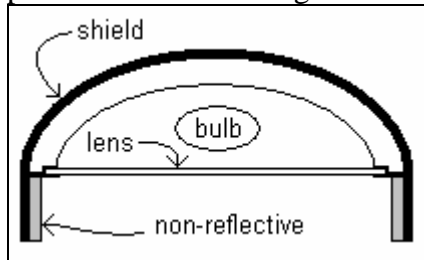

**Vertical cross section of fixture with *full oblique shielding***

The illumination does not project into protected property:



**Area lighting from fixture with *full oblique shielding***

Observations along the sight line to an installed fixture can determine if the fixture has full oblique shielding. Sight lines exist along the oblique boundary between the illumination cone and the shielded area above it.

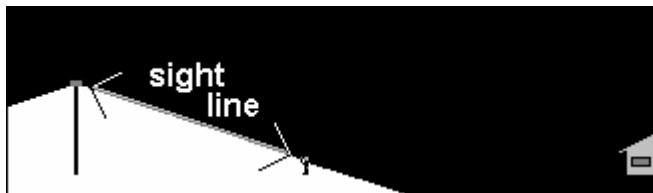

**Sight line between observer and light source**

An observer can establish a sight line at any location where the observer can see only a small part of the fixture's light source. By moving away from the fixture until the light source no longer appears, the observer will cross the sight line. Where the observer's eyes coincide with the sight line, the observer can project the sight line to the ground. The sight line coincides with the oblique line along the bottom of the shielding angle (see definition). If the sight line falls on protected property, then the fixture does not provide adequate full oblique shielding.

*Light source (Outdoor Lighting).* The medium producing the visible light or changing the direction of the light. Such media may include bulbs, lenses, refractors, reflectors, diffusers, or any emitter of visible light either directly from the material discharging the visible radiant energy or indirectly from material that redirects the illuminating light.

*Lumen (Outdoor Lighting).* The unit of measurement of the total visible light produced by a light source. Typically published in specifications by the manufacturer.

*Protected area (Outdoor Lighting).* An area intended for protection from outdoor lighting including any property: 1) in residential use, 2) in a residential zoning district that may develop into a residential use, 3) in a planned development zoning district that may develop into a residential use, or 4) in a public street right-of-way.

*Shield (Outdoor Lighting).* The opaque barrier on the fixture to block the light from illuminating certain distant surfaces. No light escapes through a shield.

*Shielding Angle (Outdoor Lighting).* The opaque angle shielded below the horizontal plane that runs through the bottom of the light source in a fixture with full oblique shielding. The oblique line along the bottom of the angle coincides with the sight line (see definition of full oblique shielding) along the oblique boundary between the illumination cone and the shielded area above it. Lighting plans use the shielding angles in calculations to plot projections of the sight lines onto land areas. Manufacturers of fixtures can provide specifications with shielding angles or diagrams showing vertical cross sections of the fixtures. Also, direct measurements of actual fixtures can determine shielding angles. Shielding angle and sample light ray paths in vertical cross sections of fixtures appear in the following illustrations showing examples of how to determine a shielding angle:

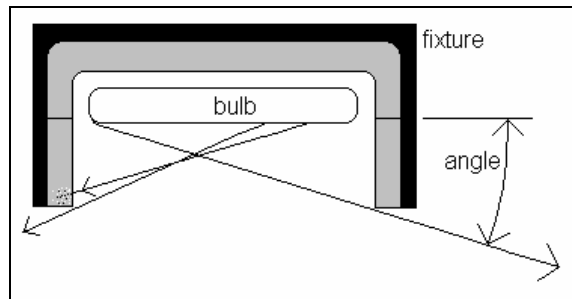

**Simple shield blocking light rays above and around sides**

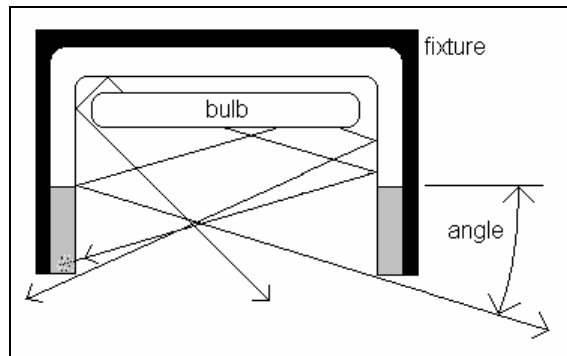

**Reflectors redirecting light rays. Shield around bottom does not reflect**

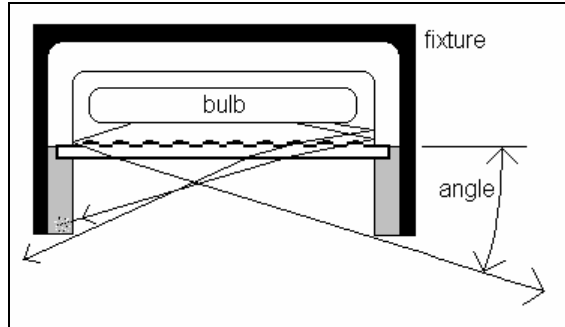

**Lens diffusing or refracting, i.e., changing direction of light rays**

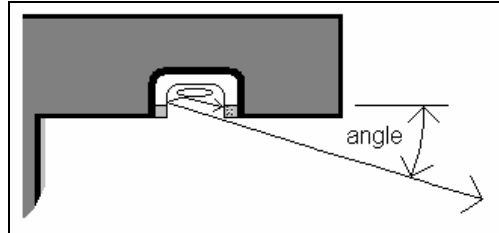

**Soffit shielding with recessed fixture**

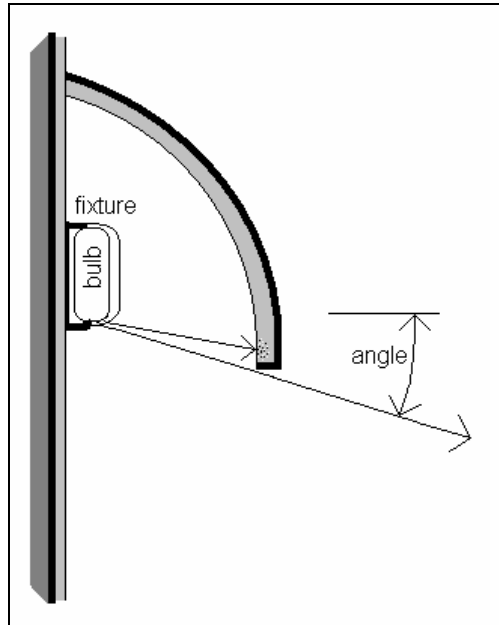

**Opaque fabric canopy or fixed-awning shielding a hidden fixture**

**Section 540. Amendments to Official Zoning Atlas.**

...

504.5. *Factors for Reviewing Proposed Amendments.* In deciding whether to recommend approval of a proposed amendment, or in deciding whether to adopt a proposed amendment, the Planning Director, Planning Commission and the Board shall consider whether the proposed amendment is consistent with the Comprehensive Plan. In particular, the Planning Director, the Planning Commission and the Board shall consider the following factors:

...

13. Will the proposed change allow uses that require so much outdoor lighting that even the light from shielded fixtures may reflect off-site with potentially adverse

effects on residential areas?

...

**Section 508. Site Plans.**

...

508.3.4. *Final Site Plan Requirements.* All Final Site Plans required by this Code shall be submitted in the number of copies required by the Planning Director, together with the required fee established by the Board. Such plans shall include the following information:

5. *Site Design*

...

- g. Plans for outdoor lighting pursuant to Section 709 and signs, if any, including the location, type, height, and area.

...

**Section 709. Lighting**

709.1. *Intent.* These outdoor lighting regulations intend to protect people and property values from the nuisance and harm of excessive outdoor lighting that:

Hinders or decreases visibility.

Glares into the eyes of drivers looking for safe nighttime visibility.

Creates a blinding brightness that leaves high-contrast, unsafely dark, shadowed areas.

Creates an artificial atmospheric glow that prevents residents from enjoying the night sky around their homes.

Spills into the yards, homes and streets of neighborhoods trying to maintain a visually calm residential character.

709.2. *Applicability.* Unless exempted in Section 709.3 *Exemptions*, these lighting regulations apply to and require a Lighting Plan for:

709.2.1. Development and redevelopment of nonresidential projects, multi-family dwelling residential projects, and common improvements in other residential projects, e.g., recreational facilities.

709.2.2. Outdoor lighting fixtures added to or intensified in nonresidential projects, multifamily projects, and common improvements in single-family residential projects, e.g., vehicle use areas and recreational facilities. Routine maintenance, e.g., cleaning and changing bulbs, ballast, starter, housing, lenses and other similar components, shall not constitute intensification provided such changes do not result in a higher lumen output compared to the fixture when new, i.e., a light brighter than the intensity of the original installation as determined by the lumen rating printed on the bulb, the shipping package, or the specification sheet.

709.3. *Exemptions:*

709.3.1. *Low Intensity* Lighting to safely illuminate street address numbers, residential building entries, residential driveways, and residential yards with light sources rated less than 800 lumens or with fixtures shielded to block direct illumination beyond these areas.

709.3.2. *Streets* Lighting to safely illuminate streets, including but not limited to their driving lanes, sidewalks, roadside recovery shoulders, and emergency lanes. Such fixtures shall have full horizontal shielding to prevent direct illumination above the

fixture and to minimize direct illumination of residences nearby.

709.3.3. *Emergency* Lighting for emergency safety repairs or natural disaster recovery.

709.3.4. *Construction* Lighting for building or site construction not exceeding ten days during any consecutive twelve months.

709.3.5. *Road and Utility Repairs* Lighting for construction, renovation, or repair of roads and utilities.

709.3.6. *Signs* Lighting for signs permitted by this Land Development Code, under the following conditions:

- a. Externally illuminated signs shall have full oblique shielding aiming the light down onto the sign.
- b. Internally illuminated signs shall comply with the Driver Vision Impairment requirements of this Section unless the signs serve only to provide driver directions without interfering with safe driver vision or traffic controls.
- c. The light from a sign shall not exceed the Measurable Spill Illumination Limits of this Section or violate the Driver Vision Impairment requirements of this Section.
- d. The extensive illuminated area of the background shall count toward the maximum sign area permitted by sign regulations.

709.3.7. *Religious or National Symbols and Flags* Lighting for religious or national symbols and flags permitted by this Land Development Code, under the following conditions:

- a. Symbols and flags that need illumination should have full oblique shielding but may have spot lights aimed up only to illuminate the symbol or flag.
- b. Internally illuminated symbols shall comply with the Driver Vision Impairment requirements of this Section.
- c. The light for a symbol or flag shall not exceed the Measurable Spill Illumination Limits of this Section or violate the Driver Vision Impairment requirements of this Section.

709.3.8. *Underwater Lamps* Underwater lamps in swimming pools and other water bodies for safety.

709.3.9. *Safety* Lighting required by government law for safety as follows:

- a. Lamps for exit signs, traffic control, waterway navigation, and aviation navigation shall have no restriction.
- b. Lamps for ramps, stairs, handicap access, boat dock decks, and other safety purposes shall have fully shielded fixtures aiming the light down onto the area requiring illumination by law.

#### 709.4.. *Illumination Limits*

709.4.1. *Direct Illumination* Unless otherwise exempted in Section 709.3, all outdoor

lighting fixtures shall have full oblique shielding so that a property's light sources do not directly illuminate another property that has an outdoor lighting protected area.

709.4.2. *Driver Vision Impairment* Lights shall not impair the vision of drivers and interfere with safe driving. A light source shall have shields to prevent it from glaring into the eyes of drivers where drivers need to see structures, signs, other vehicles, and overhead clearances to a height of sixteen (16) feet. Affected driving areas include streets, driveways, parking lots, and other vehicle use areas on-site or off-site.

709.4.3. *Measurable Spill Illumination Limits* The total illumination caused by all of a property's outdoor lighting, including light sources, diffraction, and reflections from on-site objects, shall not illuminate another property in excess of the following limits:

- a. 0.2 foot-candles on property with outdoor lighting protected areas but not including the street rights-of-way.
- b. 1.5 foot-candles on street rights-of-way because such limited coincidental illumination of a street will not constitute a nuisance to people using the street.

#### 709.5. *Fixture Height*

709.5.1. Fixture height, measured from finished grade at ground level to the bottom of the light source, determines the vertical point from which the light projects downward. Regardless of height limits, below, prevention of spill illumination may require lower heights according to calculations and plots in the Lighting Plan.

##### 709.5.2. *Limits*

709.5.2.1. All light fixtures located within 50 feet of any another property that has an outdoor lighting protected area shall not exceed 16 feet in height.

709.5.2.2. All light fixtures located within 100 feet of any another property that has an outdoor lighting protected area shall not exceed 20 feet in height.

709.5.2.3. All other light fixtures elsewhere shall not exceed 30 feet in height.

#### 709.6. *Controllers, Timers and Sensors*

709.6.1. Lights shall not illuminate when not needed. Unnecessary light constitutes a nuisance and a harm that timers, light sensors, switches, motion detectors, and occupancy sensors may prevent.

709.6.2. All electrical circuits for outdoor lighting shall have manually controlled switches conveniently located for manual operation.

709.6.3. Light sensors shall automatically turn off lights when they sense adequate daylight.

709.6.4. Timers shall automatically turn off and turn on lights when their clocks arrive at pre-set times corresponding to the times needing the lights. Alternatively, the controller may dim lights or allow fewer lights to remain on for security and safety. Motion detectors and occupancy sensors may interrupt to turn on lights for timed durations.

#### 709.7. *Special Lights*

709.7.1. *Aerial Lights* No fixture shall aim light upward to search, sweep, or move through the sky.

709.7.2. *Accent Lights* Light used to accent architectural features, fascia, landscaping, art, or similar objects shall not directly illuminate outdoor lighting protected areas. All such light shall terminate on opaque surfaces within the property.

709.7.3. *Boat Dock & Marina Lights*

709.7.3.1. All lighting for boat docks and marinas, public or private, shall provide shields to prevent spill illumination beyond the property and beyond the permitted boat docking and turning areas.

709.7.3.2. If required by government law for safe navigation, then red and green navigation lights may mark channels in the waterways.

709.7.3.3. If required by government law for safety, then lamps for boat dock decks shall have fully shielded fixtures aiming the light down onto the area requiring illumination by law.

709.7.4. *Canopy Lights* An opaque canopy, soffit, or overhang may serve as the required horizontal cut off and fixture shielding for lights fully recessed into the underside of the canopy. Such shielding shall appear as part of the Fixture Detail required on a Lighting Plan.

709.7.5. *Fascia Lights* Fascia on a canopy shall not include fixtures for outdoor lighting of the site or buildings. A sign on the fascia may include lights to illuminate the sign, but the illuminated area of the fascia shall count toward the maximum sign area permitted by sign regulations.

709.7.6. *Gas Pump, Convenience Business, Automatic Teller Machine, and other Required Security Lights* Whenever state or federal law requires certain intense illumination levels for security, then the location, intensity, quantity, height, shielding, and aim of such lights shall satisfy such requirement while still complying with these regulations, e.g., preventing direct illumination off-site, to the maximum extent possible.

709.7.7. *Outline Lights* Illuminated tubing, strings of lights, back-lighted objects, or similar fixtures that outline structures, sales areas, roofs, doors, windows, plants, or similar areas shall not light upward.

709.7.8. *Projection Lights* All projected light, laser or otherwise, shall terminate on an opaque surface.

709.7.9. *Required Lights* Whenever state or federal law requires certain illumination, e.g., safe access, then the location, intensity, quantity, height, shielding, and aim of such lights shall satisfy such requirements while still complying with these regulations, e.g., preventing direct illumination off-site, to the maximum extent possible.

709.7.10. *Stadium and Recreation Lights*

709.7.10.1. Whenever players in sporting events and recreational activities require certain intense illumination levels for safety, then the location, intensity, quantity, height, shielding, and aim of such lights shall satisfy such requirement while still complying with these regulations, e.g., preventing direct illumination off-site, to the maximum extent possible.

709.7.10.2. The illumination of outdoor recreational activities shall stop at 11:00 PM for the remainder of the night. An activity should not begin earlier if it will normally exceed this time limit. Regardless, an activity already in progress from

an earlier starting time may continue with illumination until no later than 11:30 PM. Other lower level illumination may remain for safe spectator departure and security.

709.8. *Lighting Plan*

709.8.1. *Purpose* A lighting plan shall serve to prevent excessive lighting prior to installation of the fixtures and to avoid costly compliance remedies later.

709.8.2. *Submittal* A Lighting Plan shall accompany all applications for Final Site Plan approval of development and redevelopment of nonresidential projects, multi-family dwelling residential projects, and common improvements in other residential projects, e.g., recreational facilities. When these regulations require a Lighting Plan but the project does not require a Final Site Plan, then the plan shall accompany the application for a Building Permit for electrical fixtures. Lighting Plans shall provide enough information to determine the potential for direct illumination of outdoor lighting protected areas, spill illumination, and compliance with this Section for all lighting not exempted in Section 709.3.

709.8.3. *Fixture Locations* A lighting plan shall show the horizontal position of the fixtures on the site.

709.8.4. *Fixture Detail* An inset drawing of a typical fixture shall show the directional controls, e.g., shields, reflectors, refractors, and lenses, that will aim and limit the angle of illumination. The detail shall show the vertical angle of illumination that will determine the shielding angle.

709.8.5. *Fixture Height and Mounts* The plan shall show the height of the fixtures and describe the mounts, e.g., wall, pole, or canopy.

709.8.6. *Direct Illumination Plots* For each and every fixture, the lighting plan shall use the fixture shielding angle and fixture height in calculations to plot the edge of the projection of the expected direct illumination onto the areas, both on-site and off-site, shown on the plan. The calculations and horizontal plots for each and every fixture shall appear on the plan. The horizontal plotting shall result from the following calculations based on the following illustration:

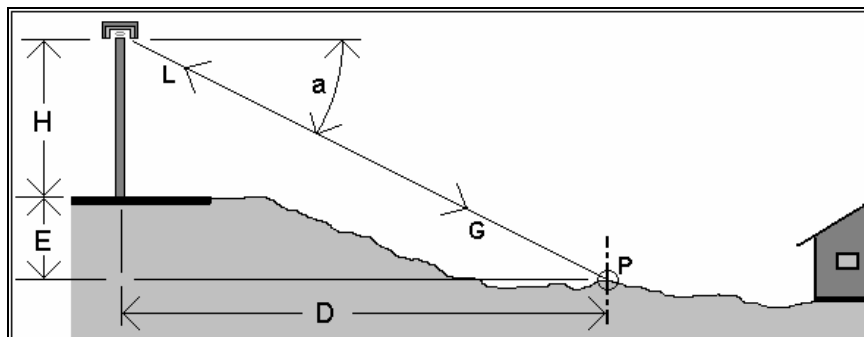

**Cross section in the vertical plane through a light fixture, pole, and grade**

Legend for symbols in illustration and calculation:

- a     shielding angle of fixture
- LG    line along the oblique boundary between the illumination cone and the shielded area above it, i.e., also the sight line between the light

- source and ground level at the edge of direct illumination
- P projection of the line LG onto the ground level, i.e., also the edge of direct illumination
- D distance horizontally from light source to P
- H height vertically from ground to bottom of light source
- E elevation difference vertically between ground level below light source and ground level at P
- / divided by
- tan trigonometric tangent function

Calculation of the distance to the edge of direct illumination:

$$D = (H + E) / \tan a$$

#### 709.8.7. *Photometric Diagram*

709.8.7.1. Any of the following conditions require that the Lighting Plan shall also include a Photometric Diagram:

- a. A projection of direct illumination within 10 horizontal feet of the property line of outdoor lighting protected areas or a street.
- b. A fixture within 80 horizontal feet of the property line of outdoor lighting protected areas or a street.
- c. A fixture higher than 20 feet above ground level within 600 horizontal feet of the property line of outdoor lighting protected areas.

709.8.7.2. A lighting engineer shall prepare the diagram.

709.8.7.3. The diagram shall plot foot-candles of illumination calculated:

- a. For the direction of the most illumination from the light sources;
- b. For a height of five (5) feet above ground level;
- c. To the nearest tenth (0.1) foot-candle; and
- d. At horizontal grid intervals of ten (10) feet.

709.8.7.4. The diagram shall cover a certain part of the affected street or property having the outdoor lighting protected area. Such part shall include the area within the circle formed with the light fixture at the center and the radius extending one hundred (100) feet into the affected street right-of-way or property of the protected area.

709.8.7.5. The plotted levels of calculated illumination shall determine if the lighting will comply with the Measurable Spill Illumination Limits of this Section.

#### 709.9. *Review*

709.9.1. The Planning Department of Manatee County shall review the Lighting Plan and determine compliance with this Section..

709.10. *Inspection*

709.10.1. The Planning Department of Manatee County shall inspect the installed lighting fixtures and determine compliance with this Section and the approved Lighting Plan.